



# H11-1



①



②



③

**A maneuverable machine with lower capacities, especially perfect for narrow marking conditions.**

- Hydraulic drive with wheel motor for infinitely variable speed regulation. Mechanical parking brake.
- Excellent visibility, both during centre and edge line markings.
- No ifs or buts: Engine compartment easily accessible for service work.
- Operator's stand can be easily tilted upward for filling the material container.
- Favourable arrangement of paint- and pressurised bead containers. Feed openings only 80 cm above the road surface. In case of paint and/or glass bead spillage no danger for the machinery.
- Extraordinary manoeuvrability. Only 2 manoeuvres are necessary to turn the machine back within a width of approx. 4,2 m.

- ① H11-1 roadmarking machine for cold paint (Airless), with pump and 120 l container
- ② H11-1 roadmarking machine for cold paint (Airless), with pump
- ③ Cold paint marker unit with rolling disks for centre markings

# H11-1



## ROAD MARKING SYSTEMS

### Technical data

3-cylinder 900 cm<sup>3</sup>  
Kubota Diesel engine,  
water-cooled  
low-emission  
Stage V resp. (US) EPA TIER 4

12,5 kW at 2800 rpm

Fuel tank: 26 l

Hydraulic oil tank: 29 l

Air output:  
up to 740 l/min at 6 bar;  
(2-cylinder compressor)

Drive unit:

- infinitely variable hydraulic drive
- acts simultaneously as service brake
- speed range:  
0 – 8,0 km/h

Pressurised glass bead container:  
65 l or (max. 0,5 bar)  
2 x 30 l (angular / max. 0,5 bar)

Turning circle:  
Ø 4,8 m  
(dependent on equipment)

Dimensions (L x W x H mm):  
2150 x 1380 x 2000  
(dependent on equipment)

Weight, equipped:  
approx. 900 kg  
*approx. 1985 lbs*

Total admissible weight:  
approx. 1300 kg  
*approx. 2866 lbs*

### Cold paints - Spraying method Airspray

Container  
up to 140 l  
(120 l or 2 x 70 l  
pressure container)

### Cold paints - Spraying method Airless

Container  
up to 140 l  
(120 l or 2 x 70 l  
pressure container)

Pressure container is suitable for equipment with one Airless pump (up to 7,5 l/min pump capacity), can be operated also unpressurised.

Version with 2 x 70 l container includes 2 x 30 l glass bead container up to max. 0,8 bar (without 65 l pressure bead container)



Easy maintainable H11-1: very good access ...

to machinery

marking of zebra crossing

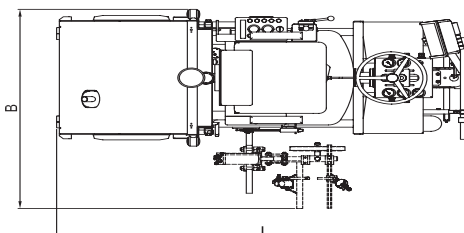
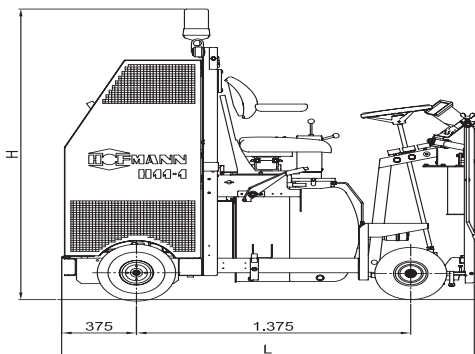

(Customised sizes upon request)