

HOFMANN 2-component swivelling extruder

2-component extruder system for application of markings on both sides of the machine

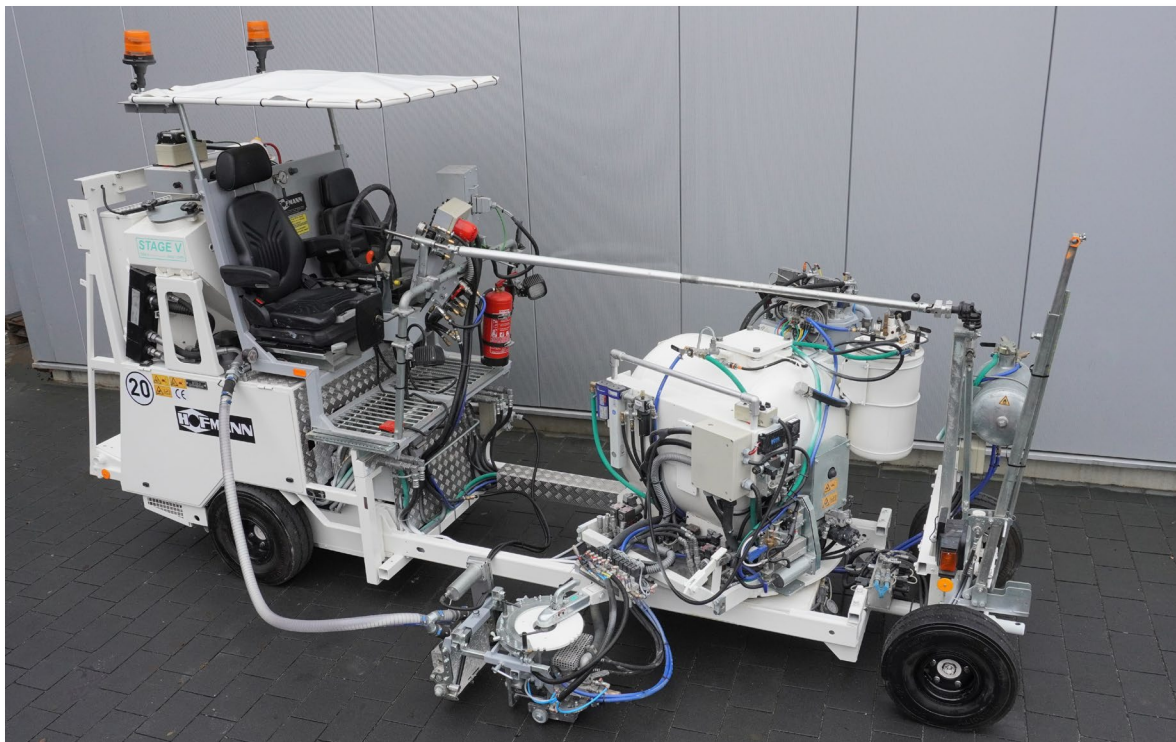

More and more countries are restricting marking against the lane direction. Reasons include matters of **traffic safety** and **traffic obstruction**.

The effort required to secure the construction site also is lower in many cases if marking does not have to be performed against the lane direction.

If you want or need to produce marking lines on both sides of the marking machine, you will have to move the extruder to the respective other side.

The innovative **HOFMANN swivel system** makes the conversion quick and simple – taking only a few minutes!

Setup:

The material container is supported turnably on the machine frame. The application unit is swiveled over above the machine frame. The container can be latched in 45° / 55° or 65° positions on either side. The entire changeover process is completed in approx. three minutes!

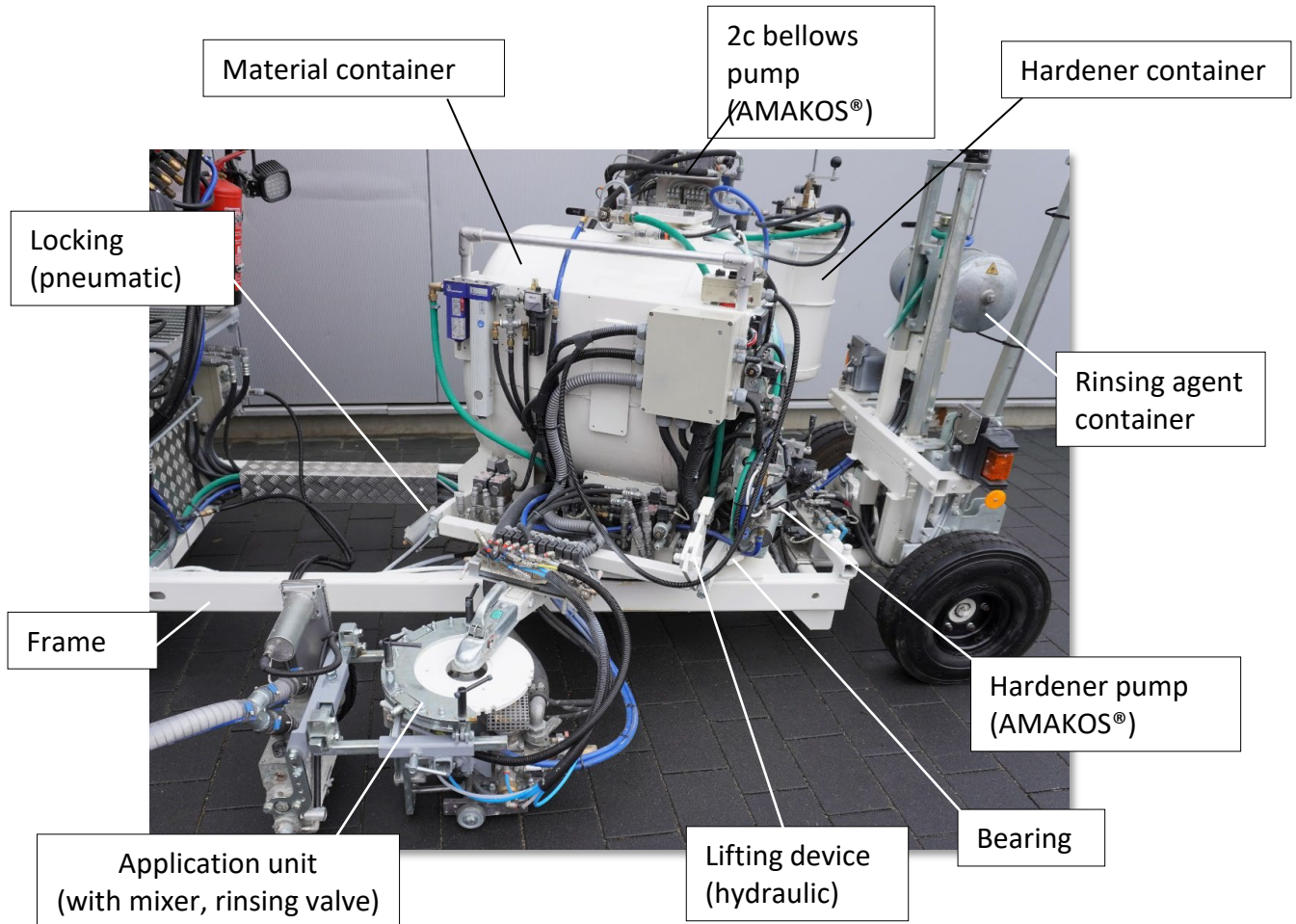

For cold plastics at a mixing ratio of 98:2

Upgrades for various marking patterns are available.



+ others

This setup has a number of advantages:

Advantage 1 – Lane direction

Application of marking lines **on both sides of the machine** → edge and center markings can always be applied in the lane direction if necessary.

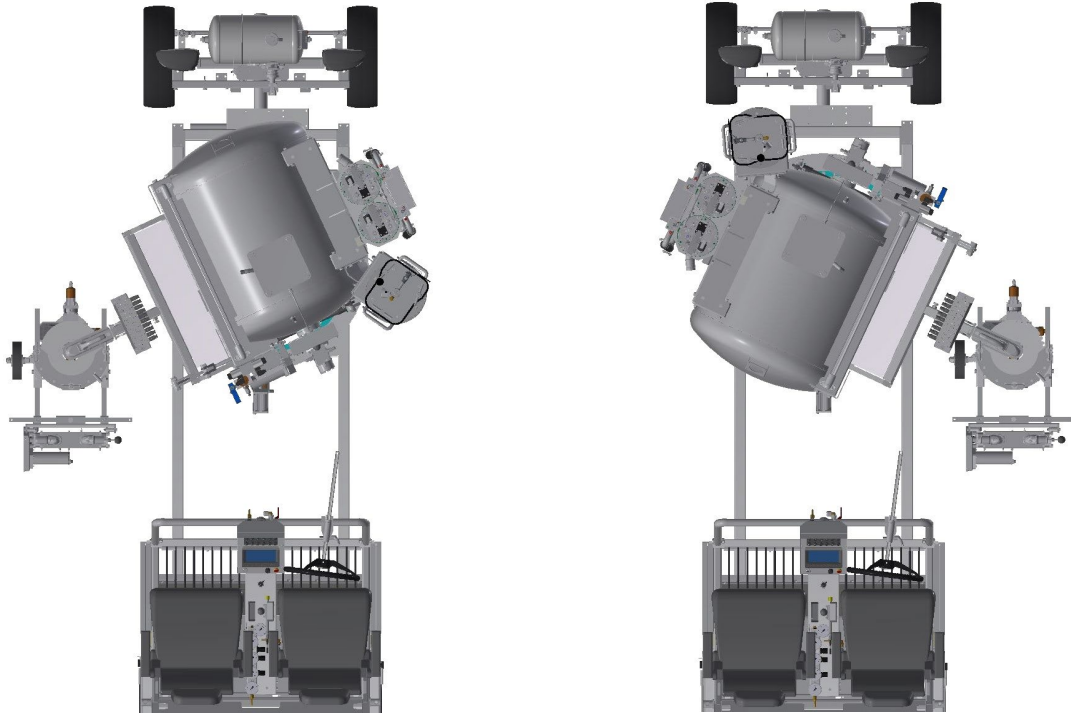

Advantage 2 – Time savings

The entire changeover process takes **just a few minutes** and can be performed easily on the construction site.

Advantage 3 – Operator friendliness

Side change requires much less conversion work than before.

The entire application unit can be lifted much farther than before (hydraulically): this improves **accessibility** of the individual system components even more – when changing equipment and during service and repair work.

Advantage 4 – Transport width

The machine is only approx. 1.5 meters wide in the transport position.

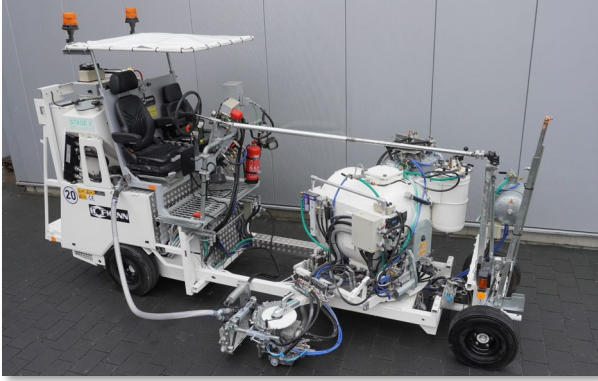

Marking position: Extruder laterally next to the tank

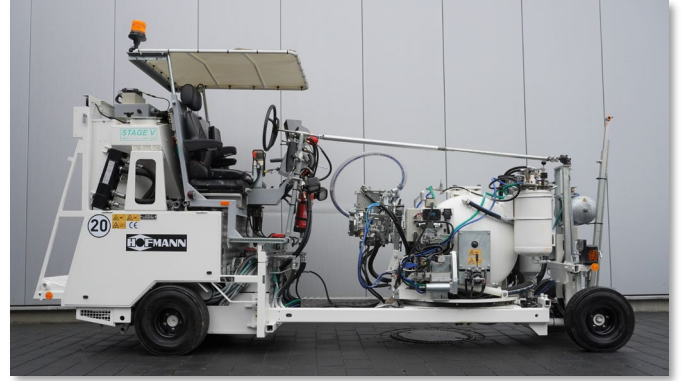

Transport position: Extruder behind the tank

Advantage 5 – Integrated 2-level lifting device

The 2-level lifting device permits operation of the extruder in the slightly raised condition as well → bad road surfaces do not transfer impacts and vibrations to the extruder head.

Advantage 6 – More consistent retroreflection values

For freeways and motorways with multiple lanes → no deviations of the retroreflection values due to marking direction. Marking both the right and left edge lines in lane direction avoids directional influence on bead formation. This is a particular advantage for structured markings.



The new swivel system makes the marking machine particularly **flexible** in use.

HOFMANN GmbH